

### SPECIFICATIONS

- Voltage rating: 250V AC, DC
- Current rating: 3A, AC, DC
- Withstanding Voltage: 1000V AC/minute
- Insulation resistance: 1000M  $\Omega$ min
- Temperature range: -25°C - +85°C
- Applicable PC board thickness: 0.063" (1.6mm)
- Contact resistance: Initial Value/10m  $\Omega$  max  
After environmental Texting/20m  $\Omega$

### HOUSING

- Part No: SCT2501H-XX
- Poles: 2-16
- Material: Nylon 66, UL 94V-2
- Q'TY: 500, 1000 pcs/bag

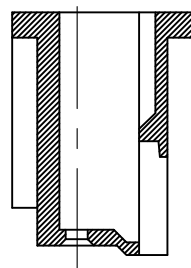
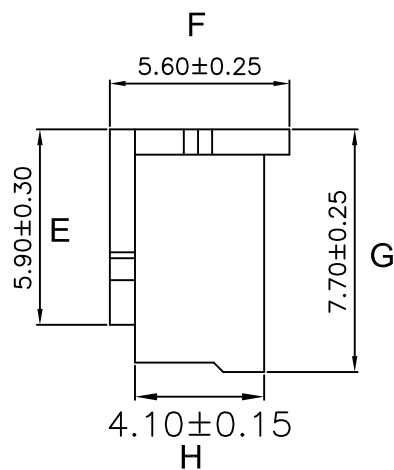
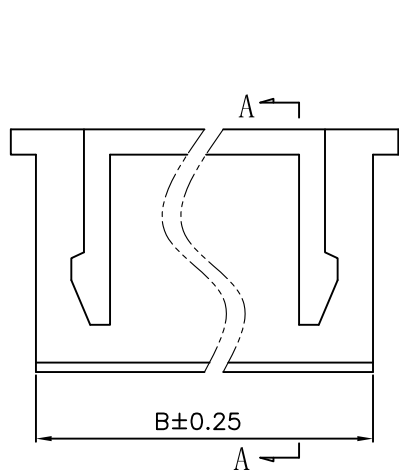
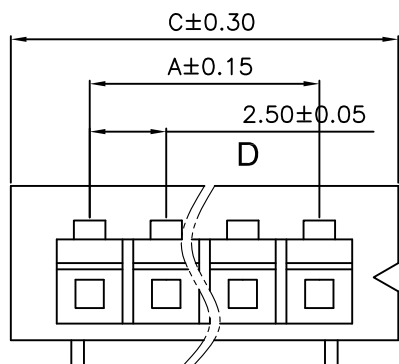

SECTION A-A

NO	PART NO	DIMENSION (mm)		
		A	B	C
1	SCT2501H-02	2.50	5.70	7.30
2	SCT2501H-03	5.00	8.20	9.80
3	SCT2501H-04	7.50	10.70	12.30
4	SCT2501H-05	10.00	13.20	14.80
5	SCT2501H-06	12.50	15.70	17.30
6	SCT2501H-07	15.00	18.20	19.80
7	SCT2501H-08	17.50	20.70	22.30
8	SCT2501H-09	20.00	23.20	24.80
9	SCT2501H-10	22.50	25.70	27.30
10	SCT2501H-11	25.00	28.20	29.80
11	SCT2501H-12	27.50	30.70	32.30
12	SCT2501H-13	30.00	33.20	34.80
13	SCT2501H-14	32.50	35.70	37.30
14	SCT2501H-15	35.00	38.20	39.80
15	SCT2501H-16	37.50	40.70	42.30

REV	DATE	MODIFICATION DESCRIPTION	CHANGE	APPROVE	OPERATION	DRAW	CHENA	05/12/27	SCALE	UNIT	mm	PART NO.	SCT2501H-XXP
0	05/12/27	NEW			~ 10	±0.15	DESIGN		SIZE	A4		TITLE:	XH2.5 HOUSING
					20 ~ 30	±0.30	CHECK	MICKY	05/12/28	SHEET	1/1	DRAWING NO.	SCT2501
					30 ~	±0.50	APPROVE	HELLEN	05/12/28	PROJ.	☯		
					Angle	± 2'							
					DIM	TOL							

**SCONDAR** 森康达电子有限公司  
SCONDAR ELECTRONIC LIMITED