

1 2 3 4 5 6 7 8 9 10

A
B
C
D
E
F
G

A
B
C
D
E
F
G

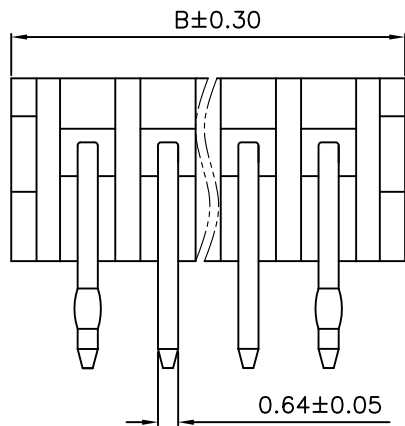
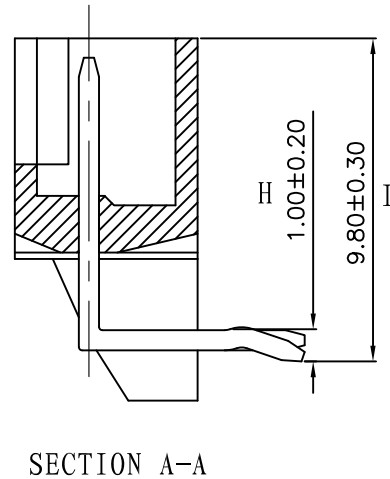
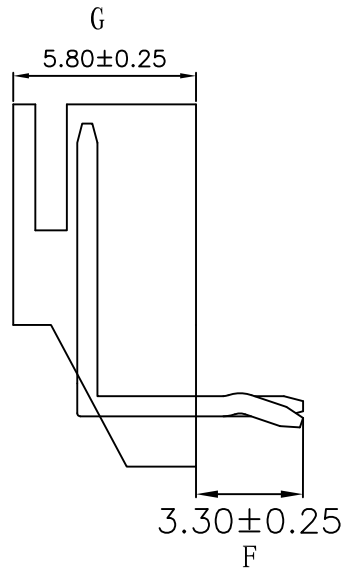
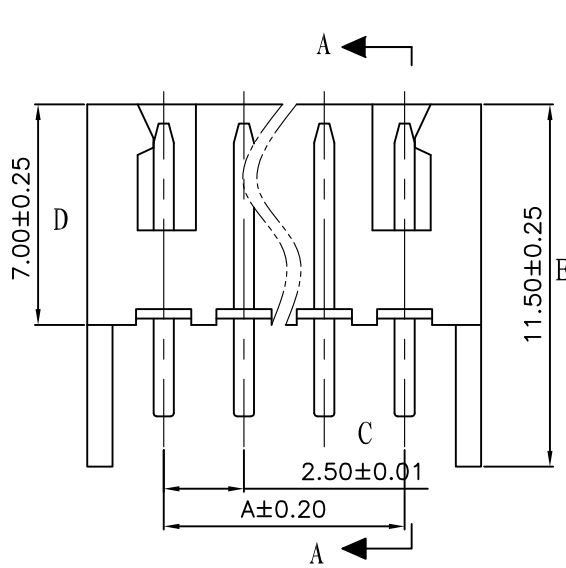

WAFER

- Part No: SCT2501WR-XXP
- Poles: 2-15
- Material: Nylon 66, UL94V-2
- Q' TY: 500, 1000 pcs/bag

SPECIFICATIONS

- Voltage rating: 250V AC, DC
- Current rating: 3A, AC, DC
- Withstanding Voltage: 1000V AC/minute
- Insulation resistance: 1000M Ωmin
- Temperature range: -25 °C - +85°C
(including temperature rise in applying electrical current)
- Applicable PC board thickness: 0.063 (1.6mm)
- Contact resistance: Initial Value/10m Ωmax
After environmental Texting/20m Ω

NO	PART NO	DIMENSION (mm)	
		A	B
1	SCT2501WR-02	2.50	7.50
2	SCT2501WR-03	5.00	10.00
3	SCT2501WR-04	7.50	12.50
4	SCT2501WR-05	10.00	15.00
5	SCT2501WR-06	12.50	17.50
6	SCT2501WR-07	15.00	20.00
7	SCT2501WR-08	17.50	22.50
8	SCT2501WR-09	20.00	25.00
9	SCT2501WR-10	22.50	27.50
10	SCT2501WR-11	25.00	30.00
11	SCT2501WR-12	27.50	32.50
12	SCT2501WR-13	30.00	35.00
13	SCT2501WR-14	32.50	37.50
14	SCT2501WR-15	35.00	40.00
15	SCT2501WR-16	37.50	42.50

REV	DATE	MODIFICATION DESCRIPTION	CHANGE	APPROVE	OPERATION	DRAW	CHENA	05/12/27	SCALE	UNIT	mm	PART NO.	SCT2501WR-XXP
1	10/12/20	E=3.40变更为E=3.30MM			~ 10 ±0.15	DESIGN			SIZE	A4		TITLE:	XH2.5 90C WF
0	05/12/27	NEW			20 ~ 30 ±0.30	CHECK	MICKY	05/12/28	SHEET	1/1		DRAWING NO.	SCT2501
					30 ~ ±0.50	APPROVE	HELLEN	05/12/28	PROJ.	◆			

SCONDAR 森康达电子有限公司
SCONDAR ELECTRONIC LIMITED

1 2 3 4 5 6 7 8 9 10